

# Make and use Compost

## SAVE TIME AND \$\$\$\$\$

### What you need

To create a **bin** for your compost:

- Pallets
- Cement blocks
- Fencing materials
- Anything sturdy

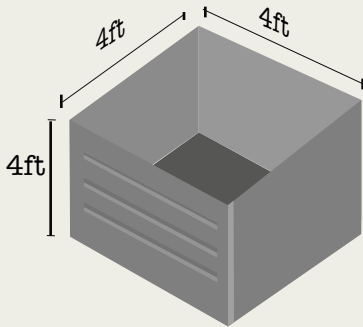

### Compost Materials

- Grass clippings
- Kitchen scraps
- Old hay
- Leaves
- Old plants

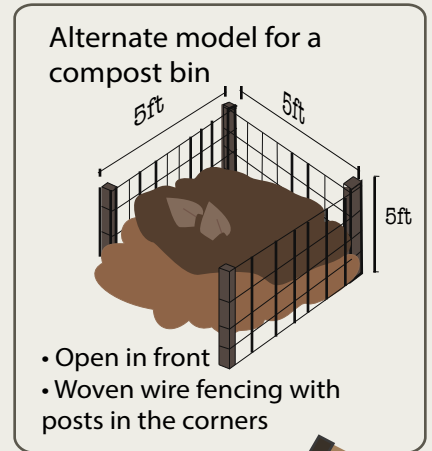

Composting aided by  
Bugs, Bacteria and Fungi

### What you do

- 1 **Add** compost materials as layers to the bin.
- 2 **Cover** kitchen scraps with grass clippings, leaves or old hay. This will help to keep the critters away!
- 3 **Wait.** Compost takes time. Give it a few months or even a year. The material at the bottom will be ready when most everything looks the same (it will be hard to identify any original materials).

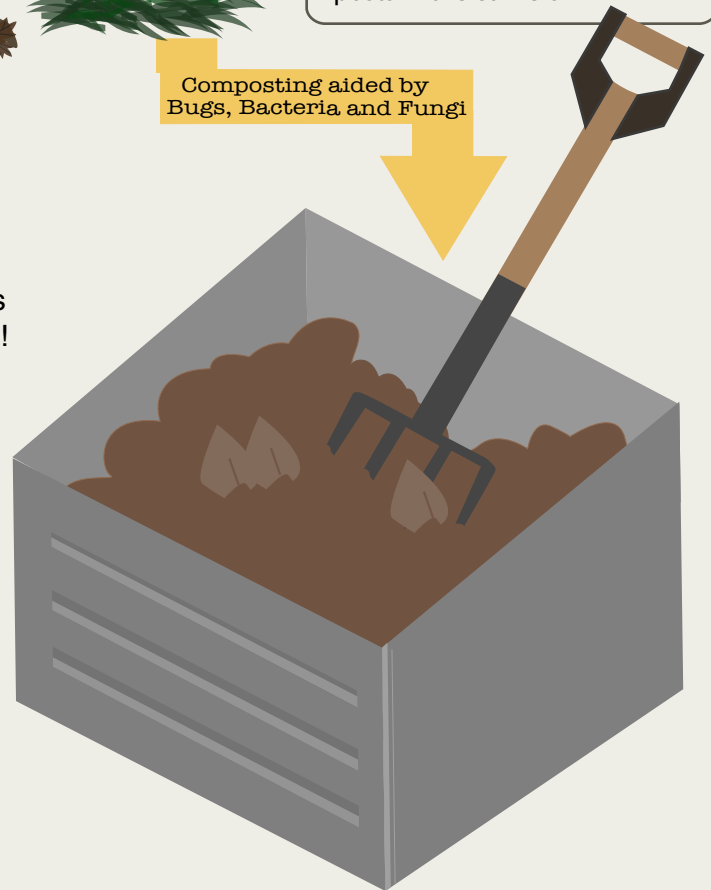

### When your compost is ready

- 1 Remove the top layer of un-composted material and start a new pile.
- 2 Spread a 2-3 inch layer of compost over the garden.
- 3 Pick out un-composted materials.
- 4 Use a tiller, garden fork, or shovel to work compost into your garden when the soil is not too wet.\*\*

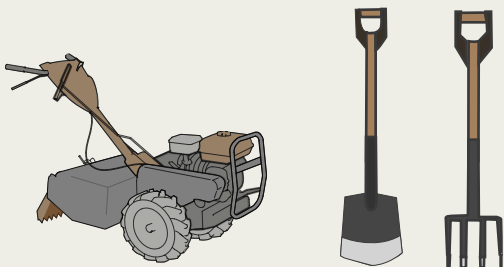

\*\* **Test the soil for wetness** by picking up some soil and making a soft fist.

Does the soil break apart when poked?

Soil is:   
READY to use!

Does the soil stay in a clump?

Soil is:   
Too wet. WAIT for soil to dry out.